

Food & Beverages
Chemistry
Petrochemistry
Machine Construction
Raw Materials
Environment
Special Engineering

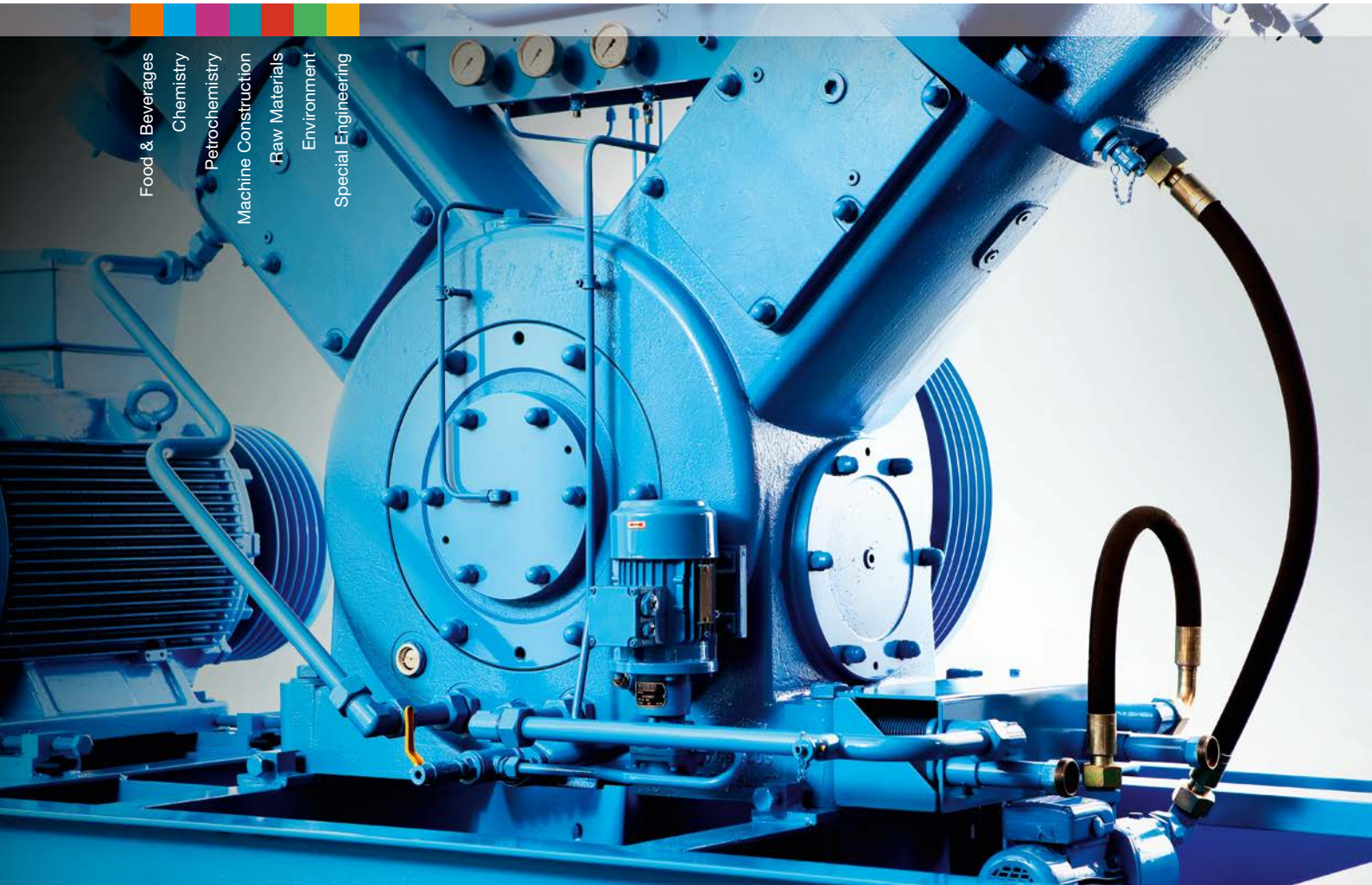

Multi-Stage, Water-Cooled Compressors SERIES TVx 900

Compressors in the TVx 900 model series are available in single-, two- and three-stage designs. A booster version is also available in this series. Compressors in this series are used in the process gas industry. They are developed to compress technically complex gases reliably.

TVx 900 compressors are used primarily in the following sectors:

- Environment
- Special Engineering
- Petrochemistry
- Chemistry
- Food & Beverages
- Machine Construction
- Raw Materials

The most important advantages:

- 100% oil-free compression without the use of filters
- Water-cooled
- Low maintenance
- Durable
- Efficient
- Robust
- API oriented
- Risk assessment according to DIN EN ISO 12100

Our Experience – YOUR BENEFITS

■ Technical data

Series	TVE 900	TVZ 900	TVB 900	TVD 900
Description	1-stage, double-acting	2-stage, double-acting	1-stage, double-acting	3-stage, double-acting
Max. compression ratio per stage	1:6	1:5.5	1:5	1:5.5
Max. suction pressure	17 bara	65 bara	65 bara	17 bara
Max. final pressure*	17 bara	65 bara	65 bara	64 bara
Stroke volume per 1 crank revolution ($\psi = 360^\circ$)	44 437 ccm	33 724 ccm	9 637 ccm	27 686 ccm
Max. drive power on the shaft	200 kW	200 kW	200 kW	200 kW
Speed range	380 - 990 rpm	380 - 990 rpm	380 - 990 rpm	380 - 990 rpm
Arrangement of the cylinders	V-form	V-form	V-form	V-form
Type of drive	Belt driven or direct drive	Belt driven or direct drive	Belt driven or direct drive	Belt driven or direct drive
Compression of toxic and flammable gases	Possible	Possible	Possible	Possible
Compressor cooling	Water-cooled	Water-cooled	Water-cooled	Water-cooled

* Relieve pressure safety valve, operating pressure max. = 0,9 x max. final pressure

CYLINDER BLOCK

Due to the modular design of the cylinder block, the compressor can be adapted according to its compression requirements.

LANTERN

The lantern is the key to oil-free compression.

CRANK GEAR

Our extremely robust crank gear ensures high availability of the system through the crosshead design.

GAS GLAND

This assembly separates the gas section of the compressor from the drive section. It prevents gas from the compression space from getting into the lantern. The gas gland is designed according to the application.

LEAKAGE AND PURGE GAS CONNECTIONS

Due to the built-in connections, the compressor can be purged with inert gases. This allows also corrosive gases (e.g. high H₂S content) to be compressed.

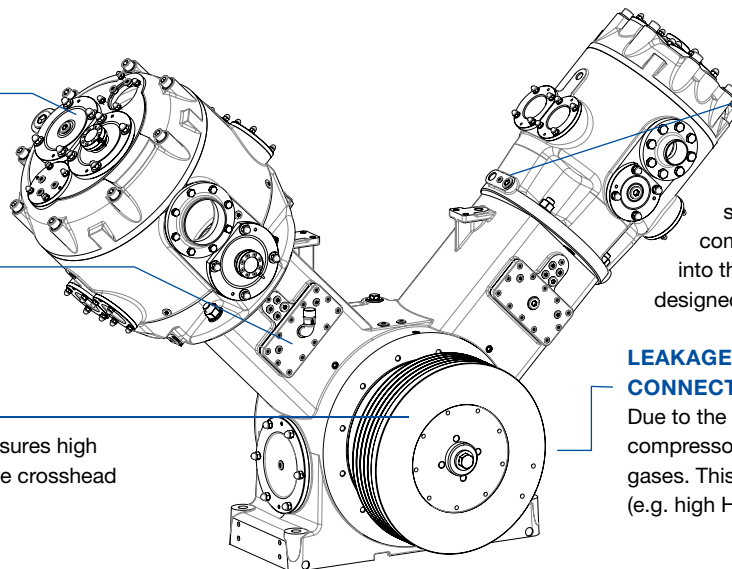

YOUR CONTACT PERSON:

Mehrer Compression GmbH

Rosenfelder Str. 35 · 72336 Balingen · Germany
Phone +49 (0)7433 2605-0 · Fax +49 (0)7433 2605-41

www.mehrer.de · info@mehrer.de